

Haier

HRF90UC



Cooled Appliance
User Manual

Safety information



WARNING: Risk of fire/flammable material.

The symbol indicates there is a risk of fire since flammable materials are used. Take care to avoid causing a fire by igniting flammable material.

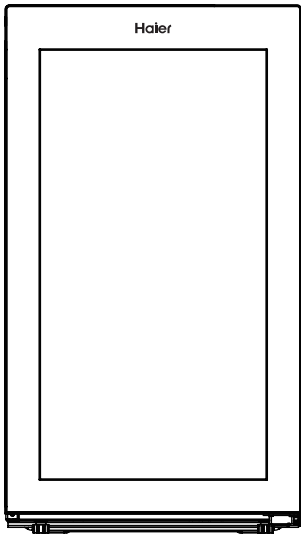

Cooled Appliance

Thank You

Thank you for purchasing a Haier Product.

Please read these instructions carefully before using this appliance. The instructions contain important information which will help you get the best out of the appliance and ensure safe and proper installation, use and maintenance.

Keep this manual in a convenient place so you can always refer to it for the safe and proper use of the appliance.

If you sell the appliance, give it away, or leave it behind when you move house, make sure you also pass this manual so that the new owner can become familiar with the appliance and safety warnings.



Legend

Warning – Important Safety information



General information and tips



Environmental information



Disposal

Help protect the environment and human health. Put the packaging in applicable containers to recycle it. Help to recycle waste of electrical and electronic appliances. Do not dispose appliances marked with this symbol with the household waste. Return the product to your local recycling facility or contact your municipal office.



WARNING!

Risk of injury or suffocation!

Refrigerants and gases must be disposed of professionally. Ensure that the tubing of the refrigerant circuit is not damaged before being properly disposed of. Disconnect the appliance from the mains supply. Cut off the mains cable and dispose of it. Remove the trays and drawers as well as the door catch and seals, to prevent children and pets to get closed in the appliance.

Old appliances still have some residual value. An environmentally friendly method of disposal will ensure that valuable raw materials can be recovered and used again.

Cyclopentane, a flammable substance not harmful to ozone, is used as an expander for the insulating foam.

By ensuring this product is disposed of correctly, you will help prevent potential negative consequences for the environment and human health, which could otherwise be caused.

For more detailed information about recycling of this product, please contact your local council, your household waste disposal service or the shop where you purchased the product, handled by the professionals.

1- Safety information.....	4
2- Safety tips.....	7
3- Maintenance	11
4-Accessories.....	13
5- Product description	14
6- Installation	15
7- Use.....	18
8- Energy saving tips	20
9 - Equipment	21
10- Care and cleaning.....	22
11- Troubleshooting	23
12- Technical data	26
13- Customer Service	27

Safety information

This product is suitable for storage of food. Please read the following safety tips before turning on the appliance for the first time.



WARNING!

Before first use

- ▶ Make sure there is no transport damage.
- ▶ Remove all packaging and keep out of children's reach and dispose them in an environmentally friendly manner.
- ▶ Wait at least 0.5 hours before installing the appliance in order to ensure the refrigerant circuit is fully efficient.
- ▶ Handle the appliance always with at least two persons because it is heavy.

Installation

- ▶ The appliance should be placed in a well-ventilated place. Ensure a space of at least 50mm above and around the appliance.
- ▶ **WARNING:** Keep ventilation openings, in the appliance enclosure or in the built-in structure, clear of obstruction.
- ▶ Never place the appliance in a damp area or location where it might be splashed with water. Clean and dry water splashes and stains with a soft clean cloth.
- ▶ Do not place in a very cold environment. Do not use outdoors and in the rain.
- ▶ Do not install the appliance in direct sunlight or in the near of heat sources (e.g. stoves, heaters).
- ▶ Install and level the appliance in an area suitable for its size and use.
- ▶ Make sure that the electrical information on the rating plate agrees with the power supply. If it does not, contact an electrician.
- ▶ The appliance is operated by a 220V-240 V/50 Hz power supply. Abnormal voltage fluctuation may cause the appliance to fail to start, or damage to the temperature control or compressor, or there may be an abnormal noise when operating. In such case, an automatic regulator shall be mounted.
- ▶ Do not use multi-plug adapters and extension cables.



WARNING!

- ▶ **WARNING:** Do not locate multiple portable socket outlets or portable power supplies at the rear of the appliance.
- ▶ **WARNING:** When positioning the appliance, ensure the supply cord is not trapped or damaged.
- ▶ Do not step on the power cable.
- ▶ Use a separate earthed socket for the power supply which is easy accessible. The appliance must be earthed.
- ▶ **Only for UK:** The appliance's power cable is fitted with 3-cord (grounding) plug that fits a standard 3-cord (grounded) socket. Never cut off or dismount the third pin (grounding). After the appliance is installed, the plug should be accessible.
- ▶ **WARNING:** Do not damage the refrigerant circuit.

Daily use

- ▶ This appliance can be used by children aged from 8 years and above and persons with reduced physical, sensory or mental capabilities or lack of experience and knowledge if they have been given supervision or instruction concerning use of the appliance in a safe way and understand the hazards involved.
- ▶ Children shall not play with the appliance.
- ▶ Children aged from 3 to 8 years are allowed to load and unload refrigerating appliances, but not allowed to clean and install the refrigerating appliances.
- ▶ Keep away children under 3 years of age from the appliance unless they are constantly supervised.
- ▶ Cleaning and user maintenance shall not be made by children without supervision.
- ▶ The appliance must be positioned so that the plug is accessible.
- ▶ If coal gas or other inflammable gas is leaking into vicinity of the appliance, turn off the valve of the leaking gas, open the doors and windows and do not unplug the power cable of the appliance.
- ▶ Wait at least 7 minutes to reconnect the power after the power has been disconnected.
- ▶ Do not lift the appliance by its door handles.

Safety information



WARNING!

- ▶ Notice that the appliance is set for operation at the specific ambient range between 10 and 43 °C. The appliance may not work properly if it is left for a long period at a temperature above or below the indicated range.
- ▶ Do not place unstable articles (heavy objects, containers filled with water) on top of the appliance, to avoid personal injury caused by falling or electric shock caused by contact with water.
- ▶ Open and close the door only with the handles. The gap between the door and the cabinet is very narrow. Do not put your hands in these areas to avoid pinching your fingers. Open or close the appliance doors only when there are no children standing within the range of door movement.
- ▶ Do not store or use inflammable, explosive or corrosive materials in the appliance or in the vicinity.
- ▶ Do not store explosive substances such as aerosol cans with a flammable propellant in this appliance.
- ▶ Do not store medicines, bacteria or chemical agents in the appliance. This appliance is a household appliance. It is not recommended to store materials that require strict temperatures.
- ▶ Do not set unnecessarily low temperature in the cabinet compartment. Minus temperatures may occur at high settings. Attention: Bottles can burst
- ▶ Do not touch the inside surface of the appliance compartment when in operation, especially with wet hands, as your hands may freeze onto the surface.
- ▶ Unplug the appliance in the event of a power interruption or before cleaning. Allow at least 7 minutes before restarting the appliance, as frequent starting may damage the compressor.
- ▶ **WARNING:** Do not use electrical devices inside the appliance, unless they are of the type recommended by the manufacturer. To avoid risks a damaged power cord must be replaced by the customer service (see warranty card).
- ▶ To prolong the service life of the appliance, avoid turning it off.
- ▶ Never place the appliance horizontally on the ground. After tilting the appliance more than 45°, wait for 24 hours before plugging it in.



WARNING!

Maintenance / cleaning

- ▶ Make sure children are supervised if they carry out cleaning and maintenance.
- ▶ Disconnect the appliance from the electrical supply before undertaking any routine maintenance. Allow at least 7 minutes before restarting the appliance, as frequent starting may damage the compressor.
- ▶ Hold the plug, not the cable, when unplugging the appliance.
- ▶ Do not clean the appliance with hard brushes, wire brushes, detergent powder, petrol, amyl acetate, acetone and similar organic solutions, acid or alkaline solutions. Please clean with soapy water to avoid damage. Rinse thoroughly with water and wipe dry. Do not use cleaning powders or other abrasive cleaners. Do not wash removable parts in a dishwasher.
- ▶ **WARNING:** Do not use mechanical devices or other means to accelerate the defrosting process, other than those recommended by the manufacturer.
- ▶ If the supply cord is damaged, it must be replaced by the manufacturer, its service agent or similarly qualified persons in order to avoid a hazard.
- ▶ Do not try to repair, disassemble or modify the appliance by yourself. In case of repair please contact our customer service.
- ▶ If the illuminating lamps are damaged, it must be replaced by the manufacturer, its service agent or similarly qualified persons in order to avoid a hazard.
- ▶ Use a Vacuum to clean the dust on the back of the unit at least once in the year to avoid hazard by fire, as well as increased energy consumption.

Safety Tips

- ▶ Do not spray or flush the appliance during cleaning.
- ▶ Do not use water spray or steam to clean the appliance.
- ▶ Do not clean the cold glass door with hot water. Sudden temperature change may cause the glass to break.
- ▶ If you leave your appliance out of use for an extended period, leave it open to prevent odour and unpleasant smells building up inside.

Refrigerant gass information



WARNING!

The appliance contains the flammable refrigerant ISOBUTANE (R600a). Make sure the refrigerant circuit is not damaged during transportation or installation. Leaking refrigerant may cause eye injuries or ignite. If a damage has occurred, keep away open fire sources, thoroughly ventilate the room, do not plug or unplug the power cords of the appliance or any other appliance. Inform the customer service.

In case of eyes get into contact with the refrigerant, rinse it immediately under running water and call immediately the eye specialist.

WARNING: The refrigeration system is under high pressure. Do not tamper with it. Since the flammable refrigerants are used, please, install, handle and service the appliance strictly according to the instruction and contact the professional agent or our after-sales service to dispose of the appliance.

Intended use

This appliance is intended to be used in household and similar applications such as

- staff kitchen areas in shops, offices and other working environments;
 - farm houses and by clients in hotels, motels and other residential type environments;
 - bed and breakfast type environments;
 - catering and similar non-retail applications.
- ▶ To ensure the safe preservation of food, please comply with this instruction for use.
- ▶ The details on the most appropriate part in the compartment of the appliance where specific types of food shall be stored, considering the distribution of temperature that can be present in the different compartments of the appliance are in the other part of the manual.

Changes or modifications to the device are not allowed. Unintended use may cause hazards and loss of warranty claims.

Safety Tips

Disposal



The  symbol on the product or on its packaging indicates that this product may not be treated as household waste. Instead it shall be handed over to the applicable collection point for the recycling of electrical and electronic equipment. By ensuring this product is disposed of correctly, you will help prevent potential negative consequences for the environment and human health, which could otherwise be caused by inappropriate waste handling of this product. For more detailed information about recycling of this product, please contact your local city office, your household waste disposal service or the shop where you purchased the product.

Since the flammable insulation blowing gases are used, please contact the professional agent or our after-sale service to dispose of the appliance.

WARNING!

Risk of injury of suffocation!

Refrigerants and gases must be disposed of professionally. Ensure that the tubing of the refrigerant circuit is not damaged before being properly disposed of. Disconnect the appliance from the mains supply. Cut off the mains cable and dispose of it. Remove the trays and drawers as well as the door catch and seals to prevent children and pets to get closed in the appliance.

- ▶ **WARNING:** Disconnect the appliance from the power supply before cleaning.
- ▶ Do not clean the appliance with hard brushes, wire brushes, detergent powder, petrol, amyl acetate, acetone and similar organic solutions, acid or alkaline solutions. Please clean with soapy water to avoid damage.
- ▶ Clean the appliance when only little or no food is stored. It is only necessary to clean it when it is dirty.
- ▶ Clean the inside and housing of the appliance with a sponge damped in warm water and neutral detergent
- ▶ Rinse with clean warm water and dry with soft cloth.
- ▶ Do not clean any of the parts of the appliance in a dishwasher.
- ▶ Allow at least 7 minutes before re-starting the appliance as frequent starting may damage the compressor.

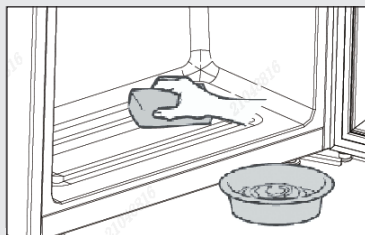

Clean the door gasket:

- ▶ The door gaskets should be cleaned every 3 months to assure a proper seal. As below : Remove: Grasp the door gasket and pull it out according to the direction of arrow to remove the whole door gasket in order.

First use a brush to clean the gasket grooves, then wipe the sealing surface with a soft damp cloth. Finally, dry the gasket with a clean towel.

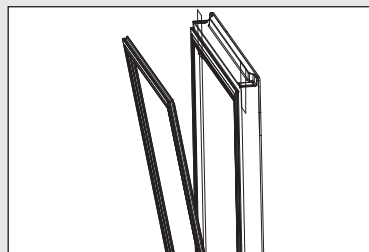

Installation of door gasket after cleaning:

Before installation, make sure that there is no water on the door gasket. Insert the door gasket into the groove, and press the door gasket tightly from the top to the bottom by hand until the whole door gasket is inserted into the groove.

Cleaning the shelves:

- ▶ All shelves can be taken out for cleaning.
- ▶ Take out all foods.
- ▶ Lift each shelf a little and take it out.
- ▶ Clean the shelf with a soft damp cloth.
- ▶ Wait until the shelves are dry before putting them back in.

WARNING:

Wait at least 7 minutes to reconnect the power after the power has been disconnected.

Accessories

Check the accessories and literature in accordance with this list:

Name	User Manual	Wine Rack	Shelf	Wire barrier
HRF90UC	1	1	2	1

Product description



Notice

Due to technical changes and different models, some of the illustrations in this manual may differ from your model.

Picture of appliance

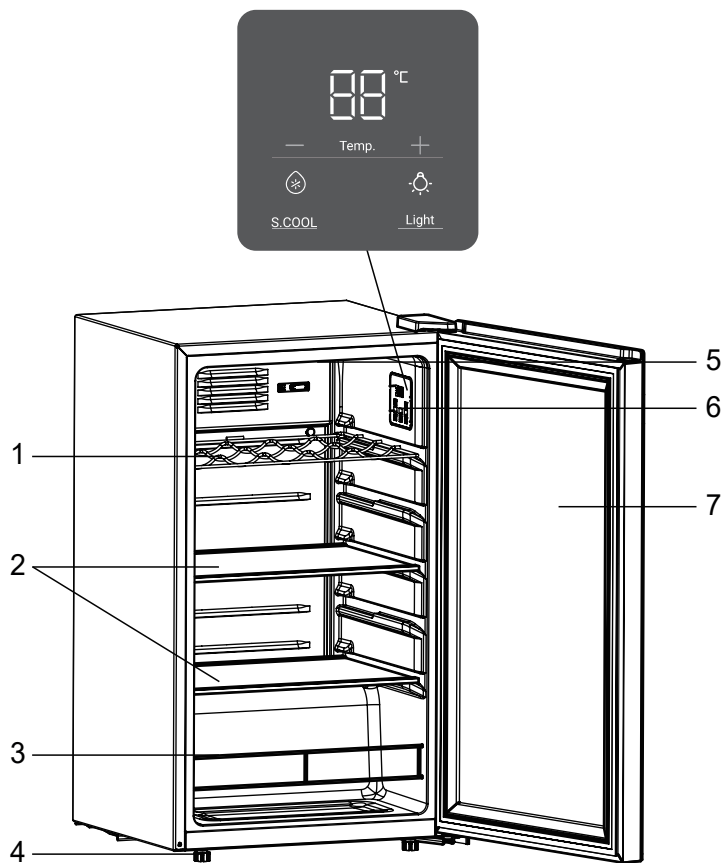

1. Wine Rack
2. Shelf
3. Wire barrier
4. Adjustable feet

5. LED Lamp
6. Display
7. Glass door

1. Unpacking

- ▶ Take the appliance out of the packaging.
- ▶ Remove all packaging materials including the foam base and all adhesive tape holding the accessories.

2. Environmental conditions

The room temperature should always be between 10 °C and 43 °C, since it can influence the temperature inside the appliance and its energy consumption. Do not install the appliance near other heat-emitting appliances (ovens, refrigerators) without isolation.

3. Space requirements

Required space to open the door (Fig. 1,2,3,4); For safety and energy reasons, the required ventilation distance of 50 mm in all directions must be observed (Fig.5).

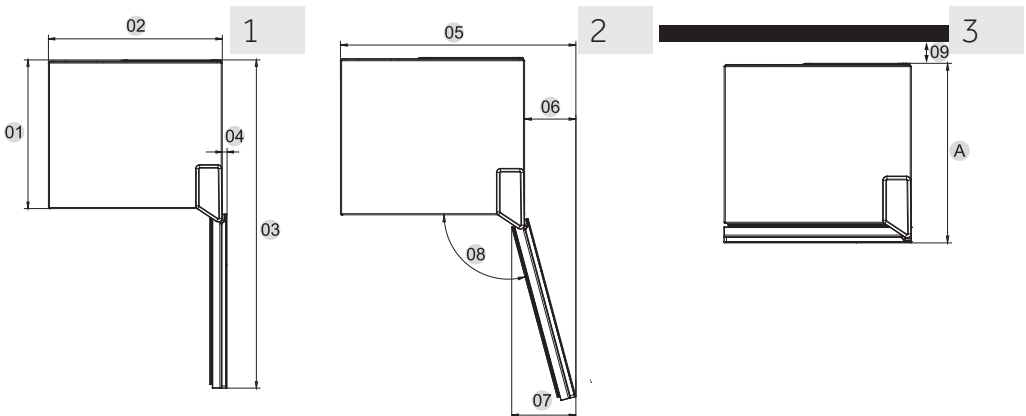

Measurement: mm	HRF90UC
Depth A	456
Width B	475
Overall Height C	850
01	406
02	475
03	897
04	13
05	608
06	133
07	166
08	105°
09	50

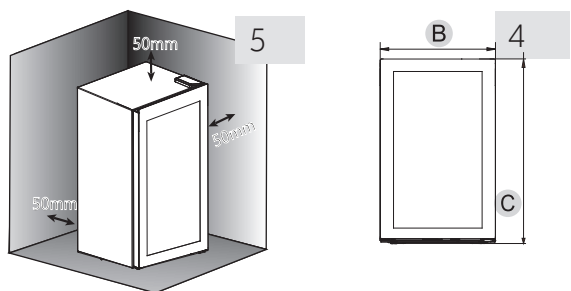

Installation



WARNING!

- ▶ Keep ventilation openings in the appliance or in the in-built structure clear of obstruction. This refrigerating appliance is not intended to be used as a built-in appliance

4. Aligning the appliance

The appliance should be placed on a flat and solid surface.

1. Tilt the appliance slightly backwards (Fig. 7).
2. Set the adjustable front feet to the desired level by turning them.
3. Check the stability by pushing on the corners and adjust as required to balance the product. If the product is not balanced the door seals may leak. Raising the front of the product slightly helps the closing of the door.

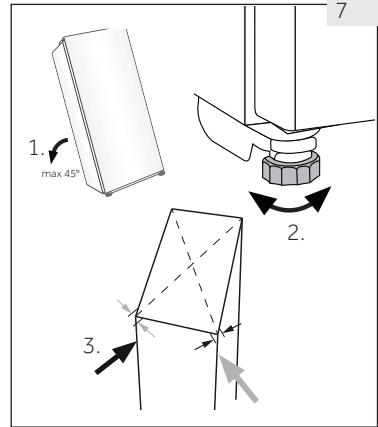

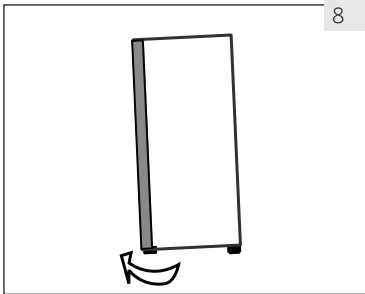

8

5. Fine tuning of the door

The appliance closes more easily if the levelling feet on the front are used:

Rotate the adjustable feet (Fig. 8) to turn them up or down:

- ▶ Turning the feet clockwise raises the appliance.
- ▶ Turning the feet counterclockwise lower the appliance.

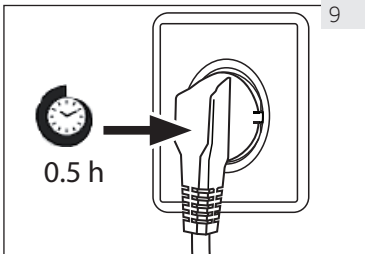

9

6. Waiting time

The maintenance-free lubrication oil is located in the capsule of the compressor. This oil can get through the closed pipe system during transport if the appliance is tilted. Before connecting the appliance to the power supply, wait 0.5 hours (Fig. 9) so that the oil runs back into the capsule.

7. Electrical connection

Before each connection check if:

- ▶ power supply, socket and fusing are appropriate to the rating plate.
- ▶ the power socket is earthed and no multi-plug or extension.
- ▶ the power plug and socket are fit properly.

Connect the plug to a properly installed household socket.



WARNING!

To avoid risks a damaged power cord must be replaced by the customer service (see warranty card).

Use

1. Before first use

- ▶ Remove all packaging materials. This includes the foam base and all adhesive tape holding the cooled appliance accessories inside and outside. Keep them out of children's reach and dispose them in an environmentally friendly manner.
- ▶ Clean the inside and outside of the appliance with water and a mild detergent before putting any beverages in it.
- ▶ After the appliance has been levelled and cleaned, wait for at least 30 minutes before connecting it to the power supply. If your appliance has been tilted for any reason, wait 24 hours before plugging it in. See section INSTALLATION.
- ▶ Once you have plugged the unit into an electrical outlet, let the unit run for at least 30 minutes to acclimatize itself before making any adjustments.
- ▶ The temperature is automatically set to 10 °C. If desired, you can change the temperature manually. Please see Temperature Setting.

2. Press key

The keys on the control panel are press buttons, which respond when lightly pressed with the finger.

3. Description for control panel

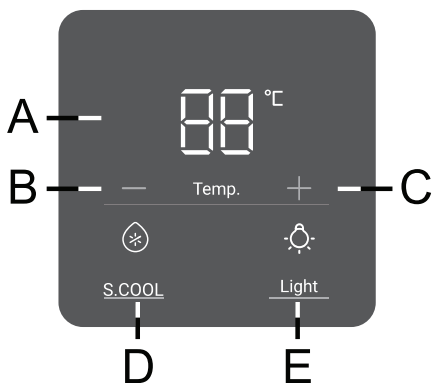

- | | |
|--------------------------------|------------------|
| A Display | D Super cool key |
| B Temperature adjust key: down | E Light key |
| C Temperature adjust key: up | |

4. Temperature setting



Notice

Presettings

- ▶ Once you have plugged the unit into an electrical outlet, let the unit for at least 30 minutes to acclimatize itself before making any adjustments.
- ▶ When the appliance is switched on after disconnection from the main power supply, it may take several hours for the correct temperatures to be reached. The exact time varies depending on the environment and the temperature setting.

Press the **B** or **C** key, the display will start to flash. Press the **B** or **C** key to set the desired temperature. The temperature setting range: -2-12°C. After 5 seconds the temperature will be confirmed.



Notice Influences on temperatures

The temperature inside the appliance is influenced by the following factors:

- ▶ Ambient temperature
- ▶ Amount of stored foods
- ▶ Frequency of door opening
- ▶ The location of the appliance

The default setting is 10°C

When the display stops blinking, the display shows the current setting temperature. If you are using to the Cooled Appliance to store food we recommend setting the product to 3 C.

5. Lighting mode setting

Press the E key to turn on the light. Press the E key again to turn off the light. The light will stay on for 10 minutes.

After the light is lit, the light will be turned off without any key operation within 10 minutes.

6. Power-Off Memory function

If a power outage, the appliance will automatically save the set temperature. After power recovery, it will run based on the temperature set before the power outage.

7. Super cooling function

When the display is on, press the "D" key, the S.Cool will light up, and the system will enter the super cooling function.

- 1) In the super cooling state, press the "D" key again, the S.Cool light is off, and the system exits the super cooling state;
- 2) After entering the super cooling function, the "S.Cool" is always lit. The super cooling function will automatically exit and return to the original set function mode if the after running for 6h.

The temperature cannot be adjusted under the super cooling function.

Energy saving tips



Energy saving tips

- ▶ Make sure the appliance is properly ventilated (see INSTALLATION).
- ▶ Do not install the appliance in direct sunlight or in the near of heat sources (e.g. stoves, heaters).
- ▶ Avoid unnecessarily low temperature in the appliance. The energy consumption increases the lower the temperature in the appliance is set.
- ▶ Open the appliance door as little and as briefly as possible.
- ▶ Do not exceed the designed amount of bottles to avoid obstructing the air flow.
- ▶ Keep door seals clean so that the door always closes correctly.
- ▶ The most energy-saving configuration requires drawer, food box and shelves to be positioned in the appliance on factory-fresh condition, and food to be placed without blocking the air outlet of the duct.

Shelf

1. The shelves are designed for easy storage and removal of beverages. They can be cleaned with a soft damp cloth.
2. The quantity can vary from the depicted number of bottles if they are stacked in a different way.

Advice for the layout of your shelf

We recommend that the number of wine bottles should not exceed two layers on each shelf, and the bearing capacity of the wine shelves should not exceed 15 kg. Before placing the bottles inside the appliance, confirm whether or not the wine shelves are completely stable. In addition, confirm whether or not any bottle protrudes from the shelves in order to prevent bottles hitting the glass door upon closing.

Notice

It is not recommended to store vegetables and other food in the product. Store beverages more than 5cm away from the duct cover to avoid blocking the air vents.

Care and cleaning

1. Defrosting

The defrosting of the appliance is done automatically; no manual operation is needed.

2. Replacing the LED lamp

DC 12V ,max Power 2W .We recommend contacting a service person to replace the LED lamp.

3. Non-use for a longer period

Unplug the power cord.

Clean the appliance and door gaskets as described above.

Keep the door open to prevent the creation of bad odours inside.

4. Moving the appliance

1. Remove all food and unplug the appliance.
2. Secure shelves and other moveable parts in the appliance with adhesive tape.
3. Do not tilt the appliance more than 45° to avoid damaging the refrigerating system.

Troubleshooting

Many occurring problems could be solved by yourself without specific expertise. In case of a problem please check all shown possibilities and follow below instructions before you contact an after sales service. See CUSTOMER SERVICE.

WARNING!

- ▶ Before maintenance, deactivate the appliance and disconnect the mains plug from the mains socket.
- ▶ Electrical equipment should be serviced only by qualified electrical experts, because improper repairs can cause considerable consequential damages.
- ▶ A damaged supply should only be replaced by the manufacturer, its service agent or similarly qualified persons in order to avoid a hazard.

Error Code	Cause	Solution
L2	Low temperature alarm when the temperature of the control sensor is too low;	Please contact our customer service.
E6	The fan in the cabinet has malfunctioned.	Please contact our customer service.

Troubleshooting

Problem	Possible Cause	Possible Solution
The compressor does not work.	<ul style="list-style-type: none"> • Mains plug is not connected in the mains socket. 	<ul style="list-style-type: none"> • Connect the mains plug.
The appliance runs frequently or runs for a too long period of time.	<ul style="list-style-type: none"> • The outdoor temperature is too high. • The appliance has been off power for a period of time. • A door of the appliance is not tightly closed. • The door has been opened too frequently or for too long. • The door gaskets are dirty, worn, cracked or mismatched. • The required air circulation is not guaranteed. • The temperature is set too low. 	<ul style="list-style-type: none"> • In this case, it is normal for the appliance to run longer. • Normally, it takes a while for the appliance to cool down completely. • Close the door and ensure the appliance is located on a level ground and there is no food or container jarring the door. • Do not open the door too frequently. • Clean the door gasket or replace them by the customer service. • Ensure adequate ventilation. • The problem will resolved itself when the desired temperature has been reached.
The inside of the appliance is dirty or smells.	<ul style="list-style-type: none"> • The inside of the appliance needs cleaning. 	<ul style="list-style-type: none"> • Clean the inside of the appliance.
It is not cold enough inside the appliance.	<ul style="list-style-type: none"> • The temperature is set too high. • Bottles have been added recently. • A door of the appliance is not tightly closed. • The door has been opened frequently or for long time. • The door gaskets are dirty, worn, cracked or mismatched. 	<ul style="list-style-type: none"> • Reset the temperature. • Allow time for recently added bottles to reach desired temperature. • Close the door. • Do not open the door frequently. • Clean the doorgasket or replace them by the customer service.
It is too cold inside the appliance.	<ul style="list-style-type: none"> • The temperature is set too low. 	<ul style="list-style-type: none"> • Reset the temperature.
Moisture formation on the inside of the refrigerator compartment.	<ul style="list-style-type: none"> • The climate is warm and damp. • A door of the appliance is not tightly closed. • The door has been opened frequently or for long time. 	<ul style="list-style-type: none"> • Increase the temperature. • Close the door. • Do not open the door frequently.

Troubleshooting

Problem	Possible Cause	Possible Solution
Moisture accumulates on the appliance outside surface.	<ul style="list-style-type: none"> The climate is too warm and too damp The door is not closed tightly. The cold air in the appliance and the warm air outside it condensates. 	<ul style="list-style-type: none"> This is normal in damp climate and will change when the humidity decreases. Ensure that the door is shut tightly and that the gaskets seal properly.
The appliance makes abnormal sounds	<ul style="list-style-type: none"> The appliance is not located on level ground. The appliance touches some object around it. 	<ul style="list-style-type: none"> Adjust the feet to level the appliance. Remove objects around the appliance.
The appliance is occasionally making a quiet hissing sound.	<ul style="list-style-type: none"> This is normal 	<ul style="list-style-type: none"> -
The interior lighting or cooling system does not work.	<ul style="list-style-type: none"> Mains plug is not connected to the mains socket. The power supply is not intact. The LED-lamp is out of order. 	<ul style="list-style-type: none"> Connect the mains plug. Check the electrical supply to the room. Call the local electricity company. Please call the service for changing
The sides of the cooler get warm.	<ul style="list-style-type: none"> This is normal. 	<ul style="list-style-type: none"> -
The door does not shut properly	<ul style="list-style-type: none"> The appliance is not level. The door is blocked. 	<ul style="list-style-type: none"> Level the appliance with the leveling feet. Check for blockages like bottles or shelves.

Technical data

Brand	Haier
Model name / identifier	HRF90UC
Category	Cooled Appliance
Annual energy consumption (kWh/annum) ¹⁾	110
Total Volume(L)	87
Climate class: This appliance is intended to be used at an ambient temperature between 10 °C and 43 °C.	S N N S T T
Airborne acoustical noise emissions (db(A) re 1pW)	37
Type of appliance	Freestanding
Dimensions (W/D/H in mm)	475/456/850

Explanations:

1)based on standard test results for 24 hours.The actual power consumption depends on the actual environment, the amount of bottling, the set temperature, the door opening and closing, etc.

2)The nominal power consumption is the value obtained according to the standard test when the wine cabinet does not turn on the internal light.

- extended temperate: 'this refrigerating appliance is intended to be used at ambient temperatures ranging from 10 °C to 32 °C';

- temperate: 'this refrigerating appliance is intended to be used at ambient temperatures ranging from 16 °C to 32 °C';

- subtropical: 'this refrigerating appliance is intended to be used at ambient temperatures ranging from 16 °C to 38 °C';

- tropical: 'this refrigerating appliance is intended to be used at ambient temperatures ranging from 16 °C to 43 °C';

Customer Service

We recommend our Haier Customer Service and the use of original spare parts.
If you have a problem with your appliance, please first check section TROUBLESHOOTING.
If you cannot find a solution there, please contact your local dealer.

HRF90UC-EN

Haier